

EASY TUNING WITH FT-817 - by Bruno Rodeghiero i3RGH

On the FAQ, the reply to the question "How do I produce a carrier for tuning my system" says:

"If in USB, you will need to change modes to AM or the like, key the microphone while tuning, and change the mode back to USB. The only mode that can safely be used to produce a legal carrier throughout the amateur bands is PKT. The number of "actions" needed to be taken during tuning typically ranges from 5 to 11"

This is very annoying!

To solve the problem, I designed a small twin-T oscillator which can be mounted inside the microphone case, in the place of the dummy "weight" which must be removed; the frequency is 1750 Hertz sinusoidal, so it can be used also for activation of VHF-UHF repeaters.

The oscillator is activated pushing both PTT and UP key (UP is not working when in TX); the circuit was mounted on a small pre-drilled PC board (1.3" x 0.4") using SMD parts (case 1206, the biggest ones.); a small wire (wire-wrap type) is used to make "flying" connections between parts where necessary.

This is the schematic:

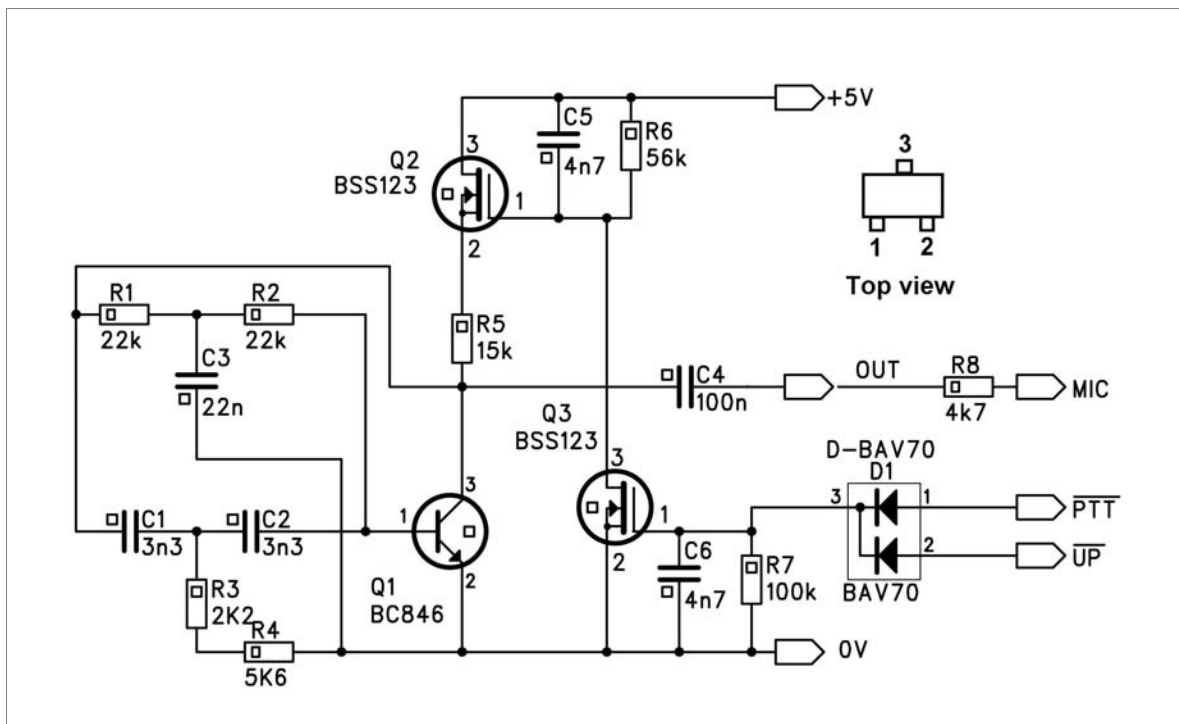

The oscillating transistor is a NPN type BC846, while two DMOS type BSS123 are used to obtain the NOR function. The following photos are details of the PC board :

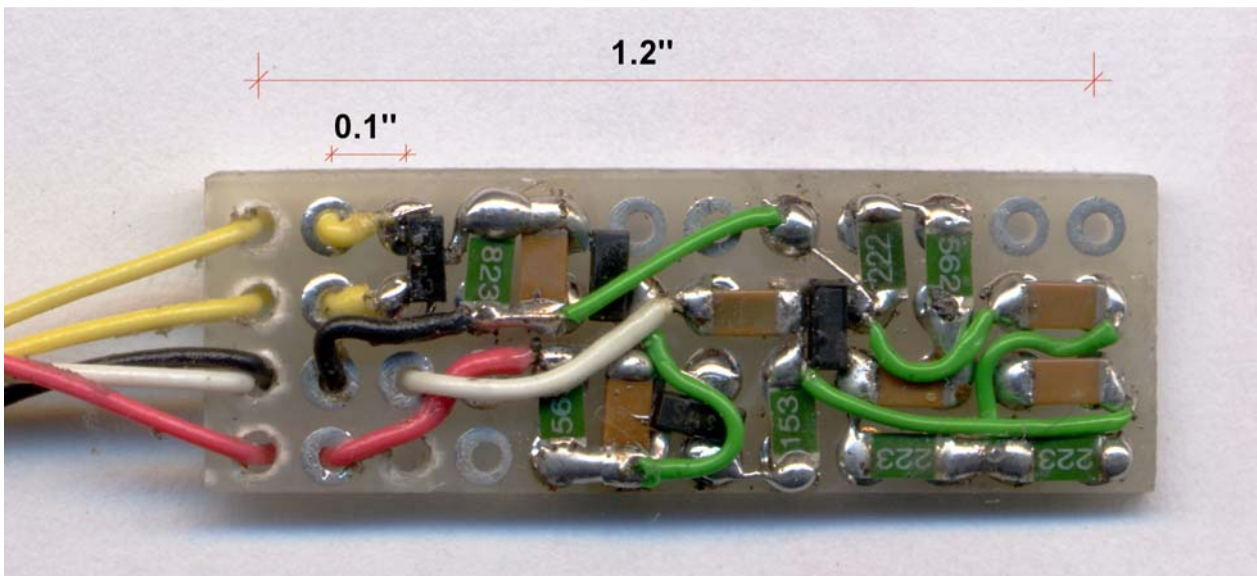

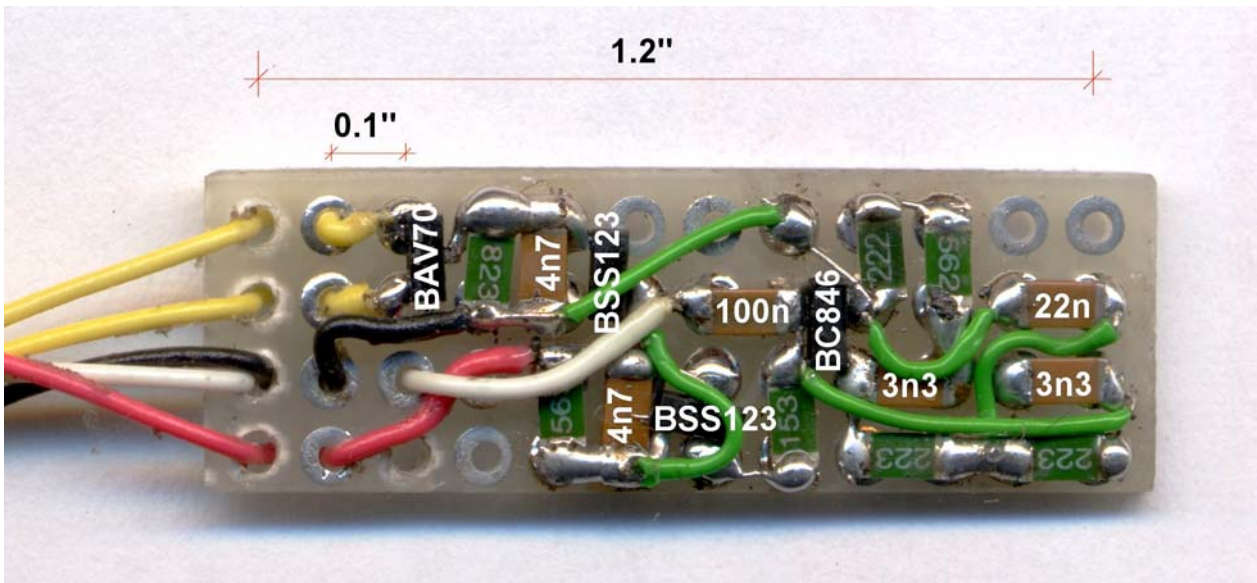

These are details of the mounting into the microphone case.
 Note that there is already a W4RT's OBP speech processor, so the signal is injected soldering the external resistor (R8) to the small PAD on OBP circuit where is connected the white (hot) wire from the microphone.

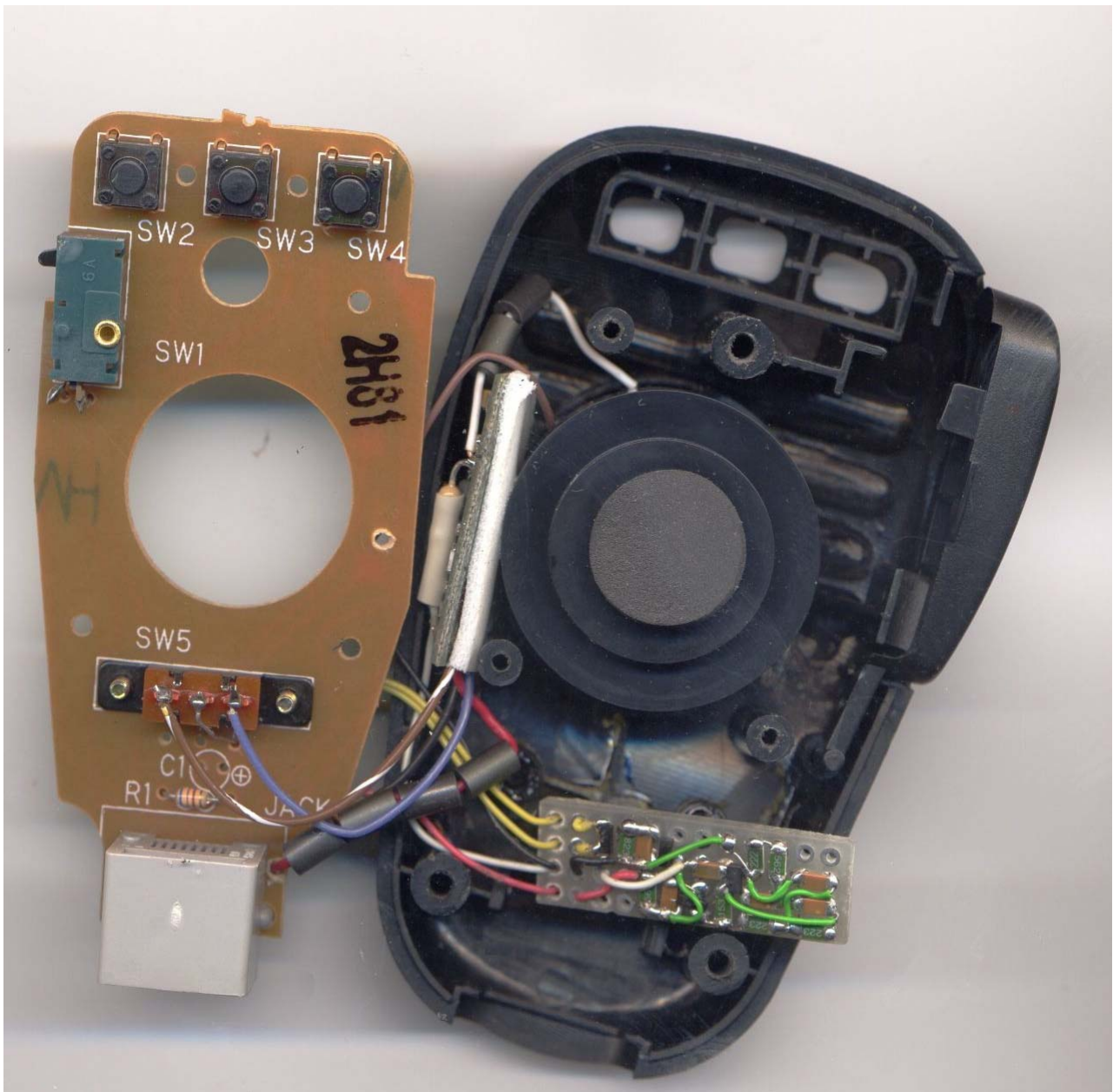

The circuit is put into a small insulating sleeve which is fixed using dual-side adhesive tape.

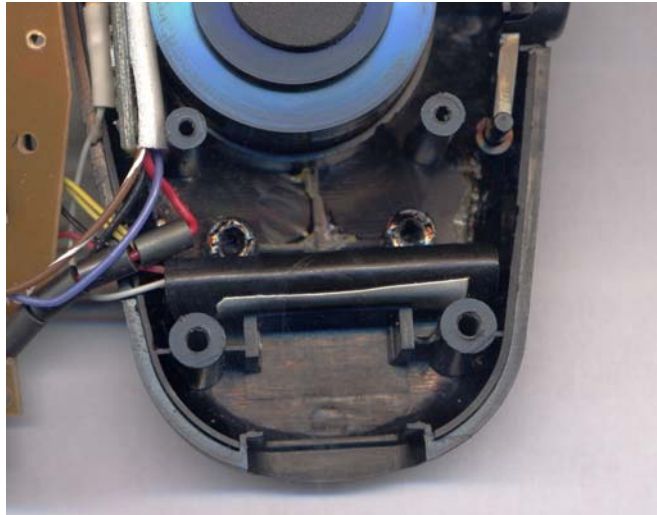

This is the wiring view; soldering to the connector must be careful.
Output wire is white; a small tubing is mounted to insulate the floating connection to R8.
Positive wire is red ; negative is black; the two activating signals (\PTT and \UP) are yellow.

