

Model V-1050

OSCILLOSCOPE

OPERATION MANUAL



HITACHI
Hitachi Denshi, Ltd.

Contents

1. Features	1
2. composition	1
3. Precautions	2
4. How to produce the bright line	5
5. Method for Connecting Signals	8
(1) When using a probe	8
(2) When a direct connect	9
(3) Caution for using the measured signal as an external trigger signal	10
6. Measuring Procedure	11
(1) DC voltage measurement	11
(2) AC voltage measurement	12
(3) Period measurement	12
(4) Measurement of time difference	13
(5) Measurement of rise (fall) time	14
(6) Measurement of single-shot signal	14
(7) Trigger of complexed waveform	15
(8) Phase shift between two signals	15
(9) Measurement by X-Y operation	16
(10) How to use TV exclusive synchronization	18
(11) Operating procedure of delayed sweep	20
(12) How to use TRIG VIEW	24
7. Panel Descriptions	25
(1) Power Supply and CRT	25
(2) Vertical deflection	26
(3) Horizontal deflection	28
(4) A triggering	30
(5) B triggering	33
(6) Miscellaneous	33
8. Specifications	35
9. Users Adjustments	39
10. Schematic Diagram	40
11. Panel Controls	49

I. Features

Hitachi Model V-1050 oscilloscope is a portable-type, advanced-class oscilloscope with a bandwidth of DC to 100 MHz. Designed by putting special emphasis on operability and ruggedness, this oscilloscope has the following features:

- (1) Wide bandwidth:
The instrument has a bandwidth from DC to 100 MHz.
- (2) High sensitivity:
Sensitivity is 500 $\mu\text{V}/\text{div}$.
- (3) Large 6" screen:
Employment of a large square CRT makes waveforms easier to observe.
- (4) Internal graticule:
Employment of internal graticule CRT permits waveforms observation to be made without parallax error.
- (5) TV synchronization:
Employment of a new TV sync/separator circuit allows instrument to observe TV signals stably.
- (6) Delayed sweep.
A portion of the signal can be magnified before observation.

(7) Trigger view:

Displays the selected internal or external trigger signal. If an external trigger signal is selected, you can correlate the time between the trigger signal and input signals.

(8) Auto focusing

Focusing shift is automatically corrected.

2. Composition

Composition of Model V-1050 oscilloscope is as follows.

- (1) Model V-1050 oscilloscope unit.....1
- (2) Probe (AT-10AE 1.5).....2
- (3) Fuse (2A for 100V and 120V set
or 1A for 220 and 240V set).....1
- (4) Dust proof cover.....1
- (5) Screw driver.....1
- (6) Power supply cord.....1
- (7) Operation Manual.....1

3. Precautions

Precautions to be observed to lengthen the service life of this instrument.

Installation site

- * Avoid installing instrument in an extremely hot or cold place.
 - o Avoid placing this instrument in a place exposed to sunlight for a long period of time, in a closed car in midsummer, or near a room heating device such as a stove.
 - o The operating maximum ambient temperature is 50°C.
- * Do not use instrument that has been left outdoors on a cold winter day. The operating ambient temperature is 0°C or more.
- * Avoid moving the instrument rapidly from a hot place to a cold place or vice versa, or condensation may form on inside of the instrument.
- * Keep the instrument away from damp air, water, and dust. Unexpected trouble may be caused when the instrument is placed in a damp or dusty place.

The operating ambient humidity is 35-85%. Since an accidental intrusion of water may also cause troubles, do not place a water-filled containers

such as a vase on the oscilloscope.

- * Do not place the instrument in a place where vibration is strong. Avoid using the instrument at a place vibrating violently. Since the oscilloscope is a precision instrument, excessively strong vibrations may cause damage.
- * Do not place the instrument near a magnet or magnetic body. An oscilloscope is an equipment using electron beam. Therefore, do not bring a magnet close to the instrument or do not use the instrument near an equipment generating strong magnetic force.

Handling

- * Do not put a heavy objects on the oscilloscope. Do not block the ventilation holes.
- * Do not apply a heavy shock to the oscilloscope.
- * Do not insert a wire, pin, etc. through the ventilation hole.
- * Do not drag the set, leaving the probe attached to it.
- * Do not leave a hot soldering iron on the cabinet or the screen.
- * Do not try to turn the instrument upside down. Otherwise, knobs may be broken.
- * Do not use the instrument upright, leaving BNC

cable connected to EXT BLANKING, GATE OUT PUT terminals on the rear panel. Otherwise, the cable may be damaged.

When Operation is faulty.

- * Recheck the operating procedure and if problem persists, contact a nearby service station or agent.

Care and Repair

- * Removal of stain from the case.
 - o When the outside of the case is stained, remove the stain by first wiping it lightly with a cloth moistened with neutral washing agent and then wipe the surface with a dry cloth.
 - o When the panel surface is stained, remove the stain in similar way with a clean, soft cloth. When heavy stains are present, first remove the stains by wiping the surface lightly with a cloth moistened with diluted neutral washing agent and then wipe thoroughly with a dry cloth.
 - o When dust has accumulated on the inside, remove it by using a dry brush, or by using the exhaust of a compressor or a vacuum cleaner.

NOTE: When opening the case, disconnect the power supply plug beforehand without fail. When cleaning the inside, insure beforehand that no electricity remains in the condensers of the power supply circuit.

- * Cleaning of CRT
 - Dirty surface of CRT screen tends to cause measuring errors.
Remove the stains on CRT and filter by using a clean and soft cloth, paying attention not to impair them.
When the stain is extremely heavy, wash them with neutral washing agent and then leave them stand until the moisture is removed naturally.
 - o If the screen is installed while it is moistened, water rings may be formed and the waveform may be blurred to become hard to observe. Pay attention not to leave finger prints on it.

Cautions to be observed before measurement

- * Check the line voltage.
The operating voltage range of this oscilloscope is as shown below. Check the line voltage without fail before turning on the power switch.

Rating	Line Voltage (50/60Hz)
AC100V	AC 90V ~ 110V
AC120V	AC108V ~ 132V
AC220V	AC198V ~ 242V
AC240V	AC216V ~ 264V

Nominal volts $\pm 5\%$ at 400Hz.

In the case of normal shipment, the voltage selector will be set convenient for user up. When it is intended to use the oscilloscope on voltages other rating, voltage selector can be turned. (Rated voltages are indicated on the rear panel of the oscilloscope.)

* Use only specified fuses.

In order to protect the circuit against over-current, a 2A (make use of AC100V or AC120V) or 1A (make use of AC220V or AC240V) is used on the primary side of the power supply. When this fuse is below out, check thoroughly the cause, repair any faulty point present, and then replace with a specified fuse. Do not try to use the fuse other than the specified ones. Otherwise, fault may be caused or danger may be invited. (Particularly, do not use a fuse different from the specified one in current capacity and in

length.) The standards if the fuses are as follows.

	Shape (Diameter \times length)mm	JIS type name
2A	6.35 ϕ \times 31.8	MF61NM250V 2A AC
1A	6.35 ϕ \times 31.8	MF61NM250V 1A AC

- * Do not increase the brightness too much. Do not increase the brightness of the spot and trace too much. Your eyes may be strained and the fluorescent surface of CRT may be burnt.
- * Do not apply an excessive voltage. The input withstand voltage of each input connector and probe input is as follows. Never apply a voltage higher than specified.

INPUT direct	250V(DC + AC peak at 1 kHz)
When probe is used	500V(DC + AC peak at 1 kHz)
EXT TRIG INPUT	250V(DC + AC peak)
EXT BLANKING	20V(DC + AC peak)

Calibration Interval

To maintain instrument accuracy, perform the calibration of the V-1050 at least every 1000 hours of operation, or every six months if used infrequently.

4. How to produce the bright line

Unless handled erroneously, this instrument will never become faulty by ordinary operation.

Before turning ON the POWER switch, insure the power supply voltage is within the range of 108V ~ 132V for AC 120V set, 198V ~ 242V for AC 220V set, and 216V ~ 264V for AC 240V set. Refer to the indication on the rear panel of the instrument for other voltages.

Connect the plug of the power cord on the rear panel into the power supply wall socket and set the knobs as follows.

POWER/INTENSITY	<input type="checkbox"/> OFF
FOCUS	Midrange
AC-GND-DC	GND
↑↑POSITION	Midrange
V.MODE	CH1
BW LIMIT 20MHZ	Full bandwidth (button out)
DISPLAY	A
↕ POSITION	Midrange
A TRIG MODE	AUTO
A TRIG COUPLING	AC
A TRIG SOURCE	CH1
A TIME/DIV	0.5ms /DIV
B TIME/DIV	Arbitrary

VAR HOLD OFF	MIN (full c.c.w.)
B TRIG MODE	AUTO

Set all the levers of the switches either to the left side or to the upper side.

After ending all the settings mentioned above, turn ON the POWER and, 15 seconds later, rotate the INTENSITY knob clockwise. Then the sweep bright line will appear.

If observation is to be started immediately, set the FOCUS knob at a point where the bright line is sharpest.

If the instrument is not used with the power supply turned on rotate the INTENSITY counter-clockwise to reduce the brightness and also blur the FOCUS.

NOTE

For usual observation, leave the following non-calibrating function section set to "CAL" position.

VARIABLE	Rotate in the direction of arrow. In this case the VOLTS/DIV is calibrated to its indicating value.
PULL SWP VAR	Push in the knob or rotate in the direction of arrow. In this case the TIME/DIV is calibrated to its indicating value.

Align the bright line with the horizontal scale line at the center of the screen by operating CH1 POSITION. In some cases the bright line may be oblique to the scale slightly by the effect of earth magnetism. In this case, bring the bright line until it lies on the horizontal scale line at the center of the screen by properly adjusting the semi-fixed variable resistor TRACE ROTATION on the front panel.

- General measurement -

- (1) In the case of observing a single waveform
 Use CH1 or CH2 when not observing the phase difference between two waveforms or when engaging in a operation other than X-Y operation.
 Make the following settings when using CH1.

MODE Switch of Vertical Axis	CH1
MODE Switch of TRIG	AUTO
TRIG SOURCE	CH1
AC-GND-DC	AC or DC

Under these settings almost all the repetitive signals of about 30 Hz or more applied to CH1 can be triggered and observed by adjusting

A TRIG LEVEL. (When, the range of TIME/DIV is between 2mS/DIV and 20ns/DIV) Since the MODE of horizontal axis is at AUTO position, the bright

line appears even when no signal is present or when AC-GND-DC switch is at GND position. This means that the measurement of DC voltage can be measured. The following switching is needed when observing low frequency signals of about 30 Hz or less.

A TRIG MODE	NORM
A TRIG COUPLING	DC

Triggering can be effected by operating LEVEL knob under this setting. When using only CH2, use the instrument after making the following settings.

MODE Switch of Vertical Axis	CH2
A TRIG SOURCE	CH2

(2) When observing two waveforms

Observation of two waveforms can be made easily by setting the MODE switch of vertical axis to ALT or CHOP. When observing two waveforms of high repetition frequencies set the MODE switch to ALT and, in the case of low frequencies, set it to CHOP. Normally, ALT and CHOP are recommended by selection of TIME/DIV.

ALT ; 0.2ms/DIV ~ 20ns/DIV

CHOP; 0.5ms/DIV ~ 0.5s/DIV

When measuring the phase difference, measure after effecting triggering with leading phase signal.

(3) When observing three or four waveforms.

This instrument can be observed the triggering signals (CH3 as A TRIG, CH4 as B TRIG) at depressed position of TRIG VIEW.

The table shows the relation between setting of vertical mode and traces on CRT.

V. MODE	No. of display
CH1	CH1, CH3
CH2	CH2, CH3
ALT	CH1, CH2, CH3, CH4
CHOP	CH1, CH2, CH3, CH4
ADD	CH1 + CH2, CH3, CH4

The displaying position of CH3 (A TRIG) is located near the 100%'s sub-graduation, and possible to adjust by A TRIG LEVEL knob. CH4 is fixed at 0%'s sub-graduation.

(4) When observing waveform with X-Y

Set the MODE switch of vertical axis to CH2 (X-Y) and DISPLAY switch to X-Y. Then the instrument works as an X-Y oscilloscope.

Each input is applied to the instrument as follows.

X-axis signal

(horizontal axis signal) CH1 INPUT

Y-axis signal

(vertical axis signal) CH2 INPUT

In this case leave the horizontal axis magnification switch (PULL × 10MAG inner shaft knob) at depressed position, and the AC-GND-DC of X-axis (CH1) to AC, also TRIG VIEW and BW LIMIT 20MHz are undepressed position (button out).

5. Method for Connecting Signals

The first step of measurement is introduce the signal desired to measure to the oscilloscope properly. Do it with utmost care.

(1) When using a probe

Use the attached probe, AT-10AE 1.5, when measuring a high frequency wave with high accuracy.

It should be noted, however, that since the input signal is attenuated by this probe to 1/10 before it is input to the oscilloscope the use of the probe is disadvantageous for low signals, and that at the same time the measuring range is extended by that amount for high signals.

<CAUTIONS>

- o Do not apply a signal which exceed 500V (DC + AC peak at 1 kHz).
- o Bring the grounding point of the earth lead wire of the probe close to the point to be measured when measuring a rapid rising signal or a high frequency signal. Long earth lead wire may cause waveform distortions such as ringing and overshoot.

Connection of earth lead wire

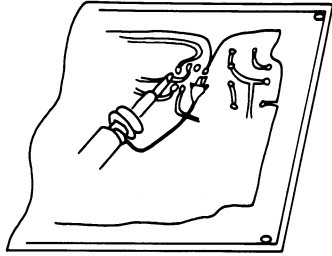

A good example

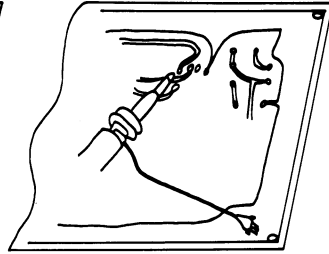

A bad example

For better measurement it is required to use an earth attachment in standard accessory of AT-10AE 1.5 probe.

- o Multiply the reading of VOLTS/DIV by 10.
For example, if the VOLTS/DIV is 50 mV/DIV, then read the waveform as
$$50\text{mV/DIV} \times 10 = 500\text{mV/DIV}$$
- o To avoid measurement error, put the probe in the following correction state and check it before measurement without fail. Connect the tip of the probe to the output terminal CAL 0.5V of 1 kHz calibration square wave voltage and an earth attachment to the GND terminal. The display should have flat tops. Any distortion in the presentation is caused by incorrect probe com-

pensation. If overshoot or undershoot is present, turn the screwdriver adjustment in the probe for a flat-top presentation.



(a) Correct



(b) Overshoot



(c) Undershoot

- (2) When a direct connection
When connecting a signal directly to the oscilloscope not using the attached probe AT-10AE 1.5 (10:1), pay attention to the following points in order to minimize the measurement error.
- o When performing observation using a bare lead wire, no trouble occurs of the circuit to be measured is of low impedance and high level. However, note that, in most cases, measurement error may be caused by static stray coupling with other circuit and power line. This measurement error cannot be ignored even

in low frequency region.

In general, it is safe to avoid measuring with non-shielded connecting wire. When using a shielding wire connect one end of the shield to the earth terminal of the oscilloscope and the other end to the grounding of the circuit to be measured. It is desirable to use a coaxial cable with BNC type connector.

- o The following cautions must be observed when performing a wide band measurement. It is necessary to terminate with the characteristic impedance of the cable when measuring a rapid rising waveform or a high frequency wave.

Especially when using a long cable, the absence of a terminating resistor will necessarily lead to a measurement error derived from ringing phenomenon. Some measuring circuits require a terminating resistor equal to the characteristic impedance of the cable also on the measurement terminal side.

BNC type terminating resistor (50 Ω) is conveniently used for this purpose.

- o In order to perform measurement with the measuring circuit put in proper operating state it is sometimes necessary to terminate the cable with

an impedance which corresponds to the circuit to be measured.

- o The stray capacity of the shield wire must be taken into account when performing measurement with a long shield wire.
Since the shield wire normally in use has a capacity of about 100 pF per meter, its effect on the circuit to be measured cannot be ignored. Use a probe to minimize the effect on the circuit.

- o When the length of the shield wire used or when the length of the non-terminated cable reaches 1/4 wave length or its multiples within the band of V-1050 type (1/4 wave length is about 0.5 meter when using a coaxial cable at 100 MHz), oscillation may be caused near 5 mV/DIV range. This is caused by the resonance between the externally connected high-Q inductance and the input capacity and can be avoided by reducing the Q. Connect the cable or shield wire to the input connector by way of a serially connected 100 Ω to 1 k Ω resistor, or perform measurement at other VOLTS/DIV range.

- (3) Caution for using the measured signal as an external trigger signal
When using the measured signal connected to the

INPUT and EXT TRIG connectors as an external trigger signal, use a divider so that the both connectors are not connected directly. Otherwise, the measuring waveform may be distorted or oscillated.

6. Measuring Procedure

The first things to do are as follows.

- o Adjusts the brightness and FOCUS in condition for easy read out.
- o Display the waveform as large as possible to minimize the read error.
- o Check the capacity correction when using a probe. (Refer to Paragraph (1) "When using a probe" of Section 5. "Method for connecting signal" for the method for correcting capacity.)

(1) DC voltage measurement

Set AC-GND-DC switch to GND and decide the zero level properly.

Set VOLTS/DIV appropriately and set AC-GND-DC to DC. Since the bright line shifts here by the amount of DC voltage, the DC voltage of the signal can be obtained by multiplying the shift width by the indicated value of VOLTS/DIV.

When VOLTS/DIV is 50 mV/DIV, then $50 \text{ mV/DIV} \times 4.2 = 210\text{mV}$ (However, if the probe AT-10 AE 1.5 (10:1) is in use, the true value of the signal becomes 10 times the value, it will be $50 \text{ mV/DIV} \times 4.2 \times 10 = 2.1\text{V}$.)

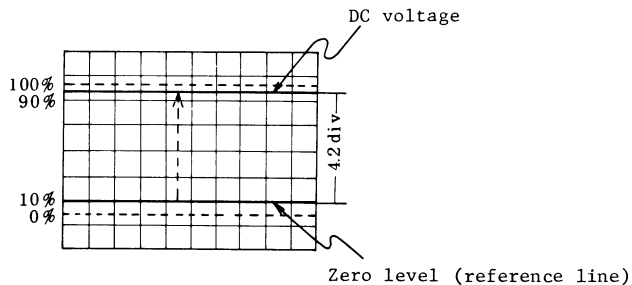

(2) AC voltage measurement

The same as paragraph 6 (1), "DC voltage measurement", but here there is no need of matching the zero level with the scale line. Move the zero level at will to a position easy to observe.

In the drawing as follows, VOLTS/DIV is 1V/DIV, $1\text{V/DIV} \times 5 = 5\text{ Vp-p}$ [50 Vp-p at using the probe AT-10AE 1.5(10:1)]. When magnifying and observing a small-amplitude signal superimposing as increases, set AC-GND-DC switch to AC. The DC voltage is cut off and AC voltage can be observed by increasing sensitivity.

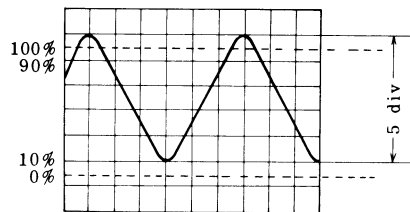

(3) Period measurement

This will be explained taking the drawing at follows as an example

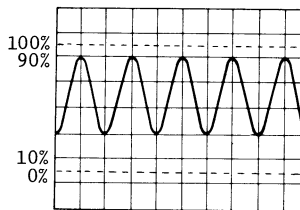

Time A Time B

One period covers the time A and time B, which are separated from each other by 2.0 DIV on the CRT.

When the sweep time is 1ms/DIV, the period is given by

$$\begin{aligned}
 1 \text{ ms/DIV} \times 2.0 &= 2.0 \text{ ms} \\
 &= 2.0 \times 10^{-3} \text{ s}
 \end{aligned}$$

Accordingly, the frequency is

$$1/(2.0 \times 10^{-3}) = 500 \text{ Hz}$$

(However, when the knob MAG $\times 10$ is at pulled out position, TIME/DIV must be converted to 1/10 since the sweep is magnified.)

(4) Measurement of time difference

Triggering signal source "SOURCE" is selected as offering reference signal when measuring the time difference between two signals. Assume that pulse trains as shown in (a). Then (b) shows the case when CH1 is taken as the triggering signal source and (c) the case where CH2 is taken.

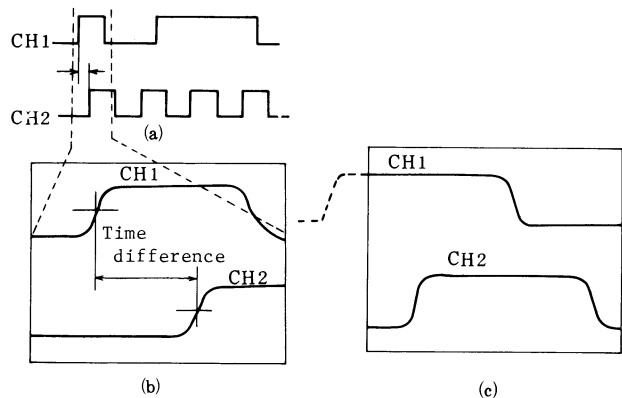

This means that CH1 is used as the triggering signal when investigating the length of time by which the signal of CH2 is delayed from the signal of CH1. CH2 is used in the reversed case. In other words, the signal leading in phase is selected as the triggering signal source.

If this process is reversed, the portion to be measured may sometimes not appear on the screen. Thereafter, equalize the amplitudes of the two signals appearing on the screen or superimpose one another.

Read the time difference by the interval between 50% amplitude points of the two signals. Sometimes the superimposing method is more convenient from the point of view of procedure.

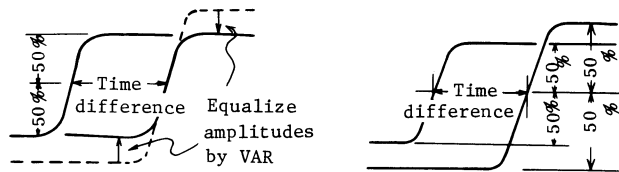

Equal amplitude measuring method Superposition measuring method

《Cautions》

Since the pulsed wave contains many high-frequency wave components (higher harmonics) depending on its width or period, pay the same attention as given to high frequency signals when handling it. Accordingly, use a probe or coaxial cable and shorten the earth lead wire as much as possible.

(5) Measurement of rise (fall) time

To measure the rise time pay attention not only to the above mentioned items but also to measurement error.

The following relationship exists between the rise time T_{rx} of the waveform to be measured, the rise time T_{rs} of oscilloscope, and the rise time T_{ro} displayed on the screen.

$$T_{rx}^2 + T_{rs}^2 = T_{ro}^2$$

When the rise time of the pulse going to be measured is sufficiently longer than the rise time of the oscilloscope (3.5ns in our case), the effect of the rise time of the oscilloscope on the measurement can be neglected. However, if both are close to each other, measurement error may be caused.

The true rise time is given by

$$T_{rx} = \sqrt{T_{ro}^2 - T_{rs}^2}$$

Moreover, in general, in a circuit free from waveform distortion such as overshoot and sag, the following relationship is established between frequency band and rise time.

$$f_c \times t_r = 0.35$$

where, f_c : Frequency band (Hz)

t_r : Rise time (s)

The rise time and fall time are determined by the time elapsed between the 10% to 90% values of pulse width.

(6) Measurement of single-shot signal

Single sweep is conveniently used in the measurement and photography of single-shot signal, waveform of remarkably non-uniform repetition (such as impulse waves, sound waves, switch noise waves). First set A TRIG MODE on the front panel to NORM and the effect synchronization by using a signal or repetitive waveform of about the same level and by rotating LEVEL.

Next, set A TRIG MODE to SINGLE and depress RESET button to insure that sweep is made on and

only one time. Then remove the vertical axis input signal (by, for example, setting AC-GND-DC switch to GND), depress SINGLE RESET and insure that READY LAMP goes on.

When apply the input signal, sweep is made for one time and READY LAMP goes out. Since sweep is also made at no signal time depending on the level, do not rotate LEVEL once SINGLE RESET is completed.

(7) Triggering of complexed waveform

In the case shown in the Fig. (a) below where waveforms greatly different in amplitude alternate, the waveform is doubled if the trigger level is not set properly. In the case where the trigger level is selected as Y line two waveforms, one starting with A and advancing to B, C, D, E, F,..... and the other starting with E and advancing to F, G, H, I....., will appear alternately on the screen. They will be doubled as shown in Fig. (b), for which no triggering can be taken.

In such a case, rotate LEVEL clockwise until the trigger level comes to Y' line. Then the waveform on the screen becomes the one is shown in Fig. (c) follow which start with B

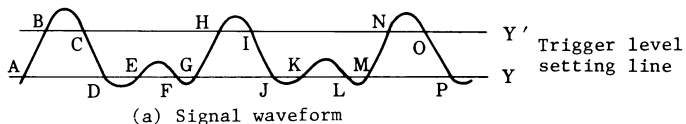

Triggering of complexed waveform

and advances to C, E, F,..... and which allows synchronization.

(8) Phase shift between two signals

To measure a phase shift between two signals of the same frequency, the dual trace display system can be utilized up to the upper limit frequency of the amplifier.

First, position both signals on the center line of the scale, e.g. just 4 div, as shown in the following figure by means of the VARIABLE and horizontal positioning knobs.

Next, set the distance where the center of the waveform of the base channel intersects with that of the scale to 8 div horizontally.

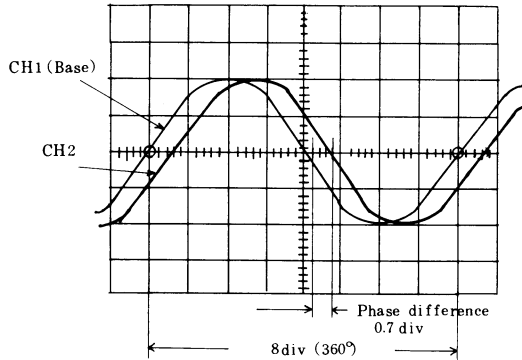

As shown in the above figure, set 1 cycle, 360° to 8 div. Then, $\frac{360^\circ}{8\text{div}} = 45^\circ/\text{div}$.

Accordingly, the phase difference in the above example can be calculated as follows:

Horizontal distance on the screen: 0.7 div
 Phase difference = $45^\circ/\text{DIV} \times 0.7 \text{ div} = 31.5^\circ$

If the portion of the phase difference is much smaller, use the MAGNIFIER at the $\times 10$ position in the above setting. At this time, 360° is displayed in $8 \text{ div} \times 10$.

Then, $\frac{360^\circ}{8 \text{ div} \times 10} = 4.5^\circ/\text{DIV}$ ($0.2 \text{ div} = 0.9^\circ$)

(9) Measurement by X-Y operation

The phase shift between two signals of the same frequency can also be measured using a Lissajou's figure by X-Y operation. A sine wave input is applied to the audio circuit being tested. The same sine wave input is applied to the vertical input of the oscilloscope, and the output of the tested circuit is applied to the horizontal input of the oscilloscope. The amount of phase difference between the two signals can be calculated from the resulting wave form.

1. Using an audio signal generator with a pure sinusoidal signal, apply a sine wave test signal at the desired test frequency to the audio network being tested.
2. Set the signal generator output for the normal operating level of the circuit being tested. If desired, the circuit's output may be observed on the oscilloscope. If the test circuit is over-driven, the sine wave display on the oscilloscope is clipped and the signal level must be reduced.
3. Connect the Channel 2 probe to the output of the test circuit.

4. Set the DISPLAY to X-Y position.
5. Connect the Channel 1 INPUT probe to the input of the test circuit. (The input and output test connections to the vertical and horizontal oscilloscope inputs may be reversed.)
6. Adjust the Channel 1 and 2 gain controls for a suitable viewing size.
7. Some typical results are shown in Fig.(b). If the two signals are in phase, the oscilloscope trace is a straight diagonal line. If the vertical and horizontal gains are properly adjusted, this line is at a 45° angle. A 90° phase shift produces a circular oscilloscope pattern. Phase shift of less (or more) than 90° produces an elliptical oscilloscope pattern. The amount of phase shift can be calculated from the oscilloscope trace as shown in Fig.(a).

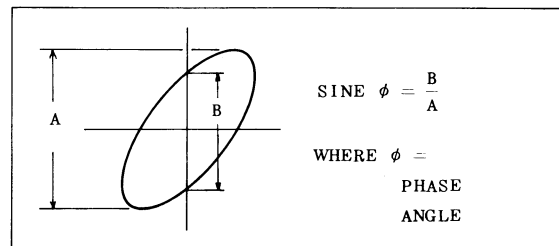

Fig.(a) Phase shift calculation







 NO AMPLITUDE DISTORTION NO PHASE SHIFT	 AMPLITUDE DISTORTION NO PHASE SHIFT
 180° OUT OF PHASE	 NO AMPLITUDE DISTORTION PHASE SHIFT
 AMPLITUDE DISTORTION PHASE SHIFT	 90° OUT OF PHASE

Fig.(b) Typical phase measurement oscilloscope displays.

(10) How to use TV exclusive synchronization

① On the image waveform of TV

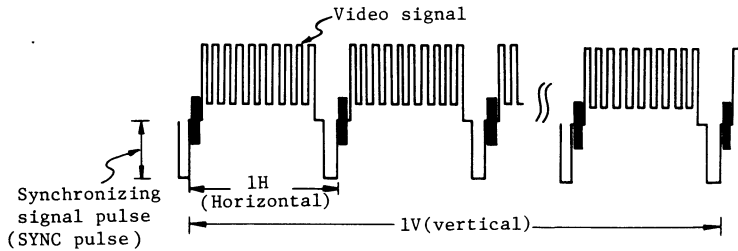

In the work concerned with TV, complexed signals containing video signal, blanking pedestal signal, and synchronizing signal are often measured. However, since the waveform is complexed, a special circuit is needed to effect a stable triggering with vertical waveform.

② Difference in the circuits

	Exclusive circuit for conventional oscillograph	Exclusive circuit for this instrument (Principle drawing)
	General circuit	Simple synchronizing circuit
	TV exclusive synchronizing separator circuit	
Circuit	<p>Video signal</p> <p>To trigger circuit</p>	<p>To trigger circuit</p>
	<p>SLOPE</p> <p>SYNC Peak Detector</p>	
	<p>Hard to synchronize because video signal is applied directly as trigger signal.</p>	<p>Synchronization is more easily effected than in the circuit shown at left, because the signal is integrated to remove high frequency components.</p>
		<p>Stable triggering was obtained, after detected the peak of SYNC pulse then the trigger level in feed back loop of operational amplifier should be fixed its SYNC tip.</p>

③ Operation

To observe vertical
signal

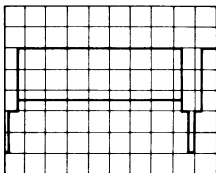

A TRIG MODE: TV
COUPLING: TV-V
LEVEL: PULL TV(-)
TIME: 0.1ms/DIV ~
0.2S/DIV

To observe horizontal
signal

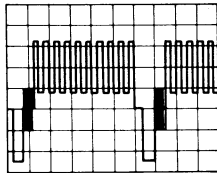

A TRIG MODE: TV
COUPLING: TV-H
LEVEL: PULL TV(-)
TIME: 50μs/DIV ~
20ns/DIV

Generally, video signal of TV has negative synchronizing signal. Use at pull out position which is A TRIG LEVEL knob. If the video signal is inverted then A TRIG LEVEL is depressed.

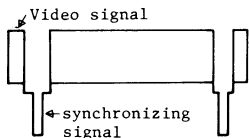

Example of

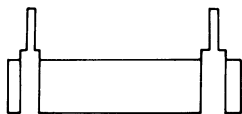

Example of

(-) synchronizing signal (+) synchronizing signal

If the sync and blanking pulses are positive, set the switch to TV(+).

(11) Operating procedure of delayed sweep

(Used to magnify and observe any portion of a complexed waveform in horizontal direction.)

There are two kinds of time delay sweep; one is AUTO time delay sweep (continuous time delay sweep) and the other TRIG time delay sweep (triggering time delay sweep). These are selected by MODE switch of B TRIG.

TRIG time delay sweep is further classified into two, the INT (CH1, CH2 internal triggering time delay sweep) and EXT (external triggering time delay sweep). Usually, the instrument is used in AUTO mode. Although the AUTO time delay sweep is easy to operate the maximum magnification factor is limited by delayed jitter (rolling) (to a few hundred times). On the other hand, since no jitter is generated in TRIG time delay sweep, this sweep has the feature of being enabled to increase the magnification factor. However, the magnification factor is limited by the brightness of CRT (to a few thousand times).

- ① At time of AUTO (continuous time delay sweep) Effect triggering by A sweep and set the knobs as follows.

B TRIG MODE	AUTO
DISPLAY	INTEN
A TIME/DIV	Choose A TIME/DIV properly
B TIME/DIV	Set B TIME/DIV at a more rapid sweep time than the one set by A TIME/DIV

Then the high brightness portion of A sweep will appear without fail (if not, adjust INTENSITY). Rotate DLY TIME POSITION knob (the center FINE is for fine adjustment). The high brightness portion will move continuously. Bring this high brightness portion to the position desired to be magnified, switch DISPLAY to B. Then the high brightness portion is magnified to occupy the full area of the screen. The sweep time is the indicated value of B TIME/DIV.

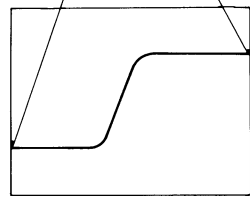
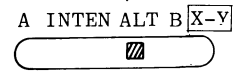
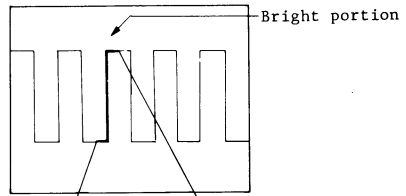
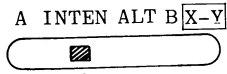

② At time of TRIG (TRIGGERING time delay sweep)
Effect TRIGGERING with A sweep and set the knobs
as follows.

B TRIG MODE TRIG (INT or EXT)
DISPLAY INTEN
A TIME/DIV Chose A TIME/DIV properly.
B TIME/DIV Set B TIME/DIV at a more rapid
sweep time than the one set by A
TIME/DIV.

SLOPE Set SLOPE either to + or to -.
Thereafter, rotate LEVEL. The high bright-
ness portion of A sweep will appear without

fail. (This state is called the B-triggered
state.) Rotate DLY TIME POSITION knob.
The high brightness portion will move con-
tinuously. Further rotation will bring this
portion to the next "peak". Therefore, bring
this high bright portion to a position
desired to be magnified and then set DISPLAY
at B. The high brightness portion is
magnified to occupy the full area of the
screen. The sweep time for this case is the
value indicated by B TIME/DIV. The gen-
locking is fixed at AC.

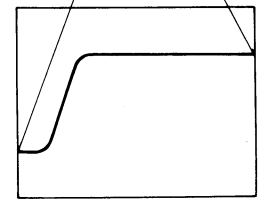
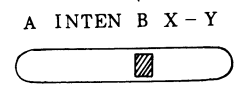
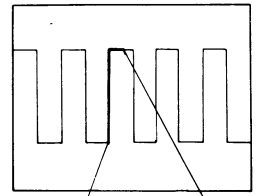
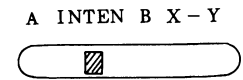

* The case in which SLOPE
is + is shown

③ ALT sweep

This ALT sweep is displayed A sweep and B (delayed) sweep alternatively. Belowing figures are showing when CH1 to be put triangle waveform and CH2 to be put rectangular waveform.

(a) Normal observation

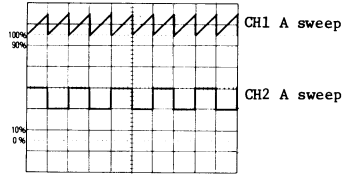
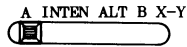

(b) Prepared to magnify

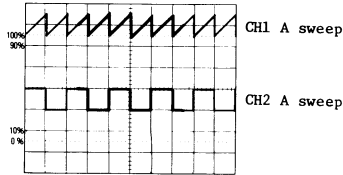
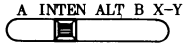

(c) (b) and intensive display in alternately sweep

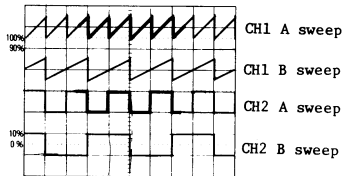

(d) Only displayed at intensive part

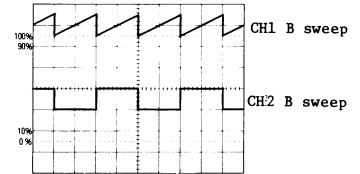
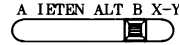

When DISPLAY switch is set the ALT, displaying signal of B sweep can be control the position to easily observe by TRACE SEP. The range of position be shift to upper and lower three divisions compare the A sweep. Then depress the TRIG VIEW switch, 4 traces come to screen in totally 8 traces to observe. These new 4 traces are A and B sweep of CH3 and CH4.

Note.

In case of ALT sweep, traces display alternately when low time-sweep operation.

Use the range of 0.2ms/DIV to higher of TIME/DIV switch.

④ Magnification of TV signal

Model V-1050 has the following three methods to select and display the magnified image of any line of TV signal.

Method Setting	Using external trigger (1)	Using external trigger (2)	Using internal trigger
A TIME/DIV	5 ms/DIV (2 ms/DIV)	Same as left	Same as left
A TRIG INPUT(CH (CH3))	Apply V synchronizing signal	Apply complexed video signal or complexed synchronizing signal (negative)	Not needed
A TRIG SOURCE	EXT	EXT	CH1 or CH2
A TRIG MODE	AUTO or NORM	TV	Same as left
A TRIG COUPLING	DC	TV-V	Same as left
A TRIG HOLD OFF	Adjust until the doubled image of fields 1 and 2 disappear	Same as left	Same as left
A TRIG LEVEL (SLOPE)	Adjust corresponding to V synchronizing signal	No operation is needed	No operation is needed
B TIME/DIV	10 μ s/DIV	Same as left	Same as left
B TRIG MODE	EXT TRIG (NOTE 1)	INT (NOTES 1 and 2)	INT (NOTES 1 and 2)
B TRIG IN (CH4)	H synchronizing signal	Not needed	Not needed
B TRIG LEVEL (SLOPE)	Adjust until the magnified portion in display	No operation is needed	No operation is needed
DISPLAY	After setting with INTEN the position to be magnified, set DISPLAY to B	Same as left	Same as left
DLY TIME MULT	Set the desired magnification position	Same as left	Same as left

(NOTE 1) AUTO is also possible. Although B TRIG needs no in this case, jitter will appear.

(NOTE 2) The separated H synchronizing signal is applied to B synchronizing circuit.

With a conventional time delay sweep oscilloscope only the method of "Using external trigger (1)" can be applicable. (In many cases this cannot be applicable.)

In Model V-1050 the methods "Using external trigger (2)" and "Using internal trigger" can be practiced besides the one mentioned above.

This make Model V-1050 very easy to operate.

(12) How to use TRIG VIEW

Vertical MODE	ALT or CHOP	
TRIG VIEW	PUSH	
A TRIG SOURCE	EXT	
A TRIG MODE	AUTO	
B TRIG MODE	EXT	(CH4 input)

Adjust A TRIG LEVEL. Then four synchronized waves can be observed.

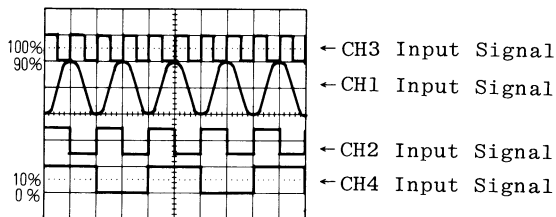

Rotate A TRIG LEVEL clockwise. The CH3 input signal on the screen moves downward (↓). Rotate A TRIG LEVEL counterclockwise. Then the input signal moves upward (↑). In this case, the TRIGGERING point is near the indicated 100% scale of the screen, A TRIG LEVEL must be adjusted to bring CH3 input signal near 100%'s line of the screen in order to effect triggering. If it shifts from the neighborhood its no triggering will be effected.

(NOTE) In some cases the waveform of trigger signal moves slightly when operating POSITION knob of CH1 and CH2. This movement will also be made when switching TRIG COUPLING from AC to DC or vice versa.

7. Panel Descriptions

(1) Power Supply and CRT

Operating voltage and fuse

This model can be operated from either a 100 volt, a 120-volt, a 220-volt or a 240-volt nominal line voltage source.

The Line Voltage Selector assembly on the rear panel converts the instrument from one operating range to the other. In addition, this assembly changes the primary connections of the power transformer to allow selection of one of four regulating ranges. The assembly also includes the line fuse. Use the following procedure to convert this instrument between nominal line voltages or regulating ranges.

1. Disconnect the instrument from the power source.
2. To convert from 100-volts nominal to 220-volts nominal line voltage or vice versa, pull out the Voltage Selector switch turn it, and plug it back into the remaining holes. Change the line-cord power plug to match the power-source receptacle.
3. Before apply power to the instrument, check that the indicating tabs on the rear panel.

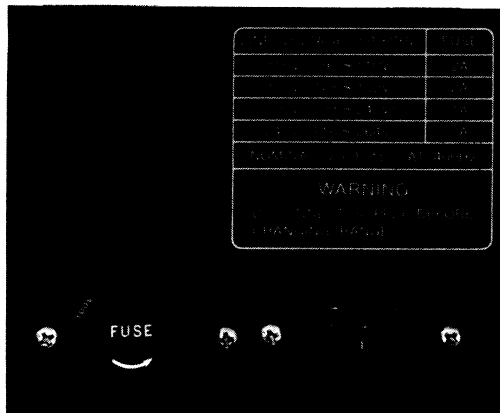

- ① POWER/INTENSITY
Turns the power on or off and controls the brightness of the CRT display. Clockwise adjustment increases brightness.
- ② Pilot lamp
Lights when the instrument power is on.
- ③ FOCUS
Provides adjustment for optimum display definition.
- ④ TRACE ROTATION
Corrects slight tilting of trace caused by external magnetic fields.

⑤ SCALE ILLUM

Controls graticule illumination. Useful to illuminate the graticule when viewing in a dark area, photographing.

⑥ TRACE FINDER

Compress display within graticule area, independently of display portion or applied signals.

(2) Vertical deflection

⑦ CH1 OR X INPUT

This is an input plug for use with the CH1 vertical amplifier and X-axis (horizontal axis) amplifier during X-Y operation.

⑧ CH2 OR Y INPUT

This is an input plug for use with the CH2 vertical amplifier and Y-axis (vertical axis) amplifier during X-Y operation.

⑨ AC-GND-DC

(Alternating Current-Ground Switch-Direct Current)

Switches the coupling of the signal fed to the vertical axis input. DC coupling is obtained on the DC position. On AC position, the direct current component is blocked by a capacitor. The GND position grounds the input of the amplifiers and opens the input terminal

⑩ VOLTS/DIV

(CH1 or X sensitivity switch)

This is a knob for switching the sensitivity of the input signal fed to CH1. Switching action is accomplished in ten steps from 5mV/DIV to 5V/DIV. On X-Y operation, the knob functions to change the sensitivity of the X-axis.

(CH2 or Y sensitivity switch)

This is a knob for switching the sensitivity of the input signal fed to CH2. Switching action is accomplished in ten steps from 5mV/DIV to 5V/DIV. On X-Y operation, the knob functions to change the sensitivity of the Y-axis. To measure by the use of the indicated voltage sensitivity, be sure to set each of the VARIABLE to CAL position by turning fully clockwise. If the signal is applied to the input terminal by the use of a 1/10 low capacitance probe, the values are ten times the indicated voltage.

⑪ VARIABLE

This is a vertical axis sensitivity fine adjustment which is capable of attenuating to less than 1/2.5 by indication of each range of VOLTS/DIV. To measure a voltage by the use of voltage sensitivity indicated by VOLTS/DIV, turn the

VARIABLE clockwise fully to CAL.

⑫ POSITION, PULL $\times 10$ MAG

CH1 $\uparrow\uparrow$ (Vertical position adjustment)

With the knob turned clockwise, the waveforms of CH-1 move upward. When the knob is turned counterclockwise, the waveforms move downward.

CH2 $\uparrow\uparrow$ (Vertical position adjustment)

Clockwise rotation will move pattern up, and counterclockwise rotation will move pattern down

When the knob is pulled, the vertical axis sensitivity at each range of VOLTS/DIV is increased by 10 times.

Note

1. When measuring at 5 mV/DIV ~ 5 V/DIV range, use the $\times 1$ (PULL $\times 10$ MAG switch is depressed position). Otherwise the S/N and frequency bandwidth of instrument will be decreased.
2. In case of the observation of signals in the high-sensitivity range of 500 μ V to 2mV/DIV and in the CHOP MODE, it is sometimes difficult to get stable synchronization due to noises caused by the high amplification of vertical amplifier. In these cases:

- a. Put a high level of signal synchronized with the observing signal into the A EXT TRIG terminal or CH2 terminal (when using CH1) as trigger signal source.
- b. In case of observing low frequency signals under 4kHz, select "HF REJ" of A TRIG COUPLING.
- c. In case of observing signals over 4kHz, select "ALT" of vertical MODE.

⑬ MODE

o CH1

Only the input signal applied to CH1 is displayed.

o CH2, X-Y

Only the input signal applied to CH2 is displayed.

o ALT

CH1 and CH2 signals are displayed alternately on consecutive sweeps.

o CHOP

CH1 and CH2 signals are displayed simultaneously by switching between channels at about 250 kHz rate.

o ADD

Displays the algebraic sum of the channel 1 and channel 2 input signals. If the channel 2 display is inverted (press CH2 INV), an CH1 minus CH2 display results.

⑭ BW LIMIT 20MHZ

The BW LIMIT 20MHZ switch provides a method of reducing interference from unwanted high-frequency signals when viewing low-frequency signals. When set it -3dB bandwidth point of the vertical deflection system is limited to about 20MHZ.

Reduces the bandwidth of channel 1 and channel 2 to approximately 20MHZ.

⑮ CH2 INV

Inverts the polarity of the channel 2. Useful to comparison of two signals of opposite polarities, and observation of a differential signal of CH1 and CH2 along with ADD mode.

⑯ TRIG VIEW

This switch is used when desiring to observe the waveform triggering signal on the screen. It is also used when measuring the phase difference between the synchronizing signal and other input signal. (Quad phenomena observation.)

(3) Horizontal deflection

⑰ DISPLAY

This switch is used to select the operation mode of the horizontal axis.

- o A A sweep appears on the screen. This setting is used in normal cases.
- o INTEN Although the sweep on the screen is A sweep it indicates B sweep (delay time sweep) by intensity modulation.
- o ALT Signals applied respectively to A sweep and B sweep appear on the screen alternately each sweep.
- o B The intensity modulated portion in INTEN mentioned above is magnified to occupy the full area of the screen. The sweep time at this time is B.
- o X-Y This position is used when using the instrument as an X-Y oscilloscope. X direction signal is input to CH1 and Y direction signal to CH2. The vertical deflection sensitivity at this time is read on CH2 VOLTS/DIV and horizontal axis sensitivity on CH1 VOLTS/DIV. Vertical position is set by CH2 POSITION and horizontal position by ↕ POSITION.

⑱ TRACE SEP

B sweep of the position adjustment knob when ALT sweep mode.

Note

The instrument has a special control system to easily observe at high speed sweep range when DISPLAY is set to ALT or B. Therefore, the traces is still remained when decrease the INTENSITY to minimum.

⑲ A TIME/DIV (Sweep speed selection)

The outer knob controls the A (Main) sweep rate, which has from 20 ns/DIV to 0.5 s/DIV selects 23 fixed sweep speeds.

⑳ B TIME/DIV

The inner knob control the B (Delayed)-Sweep rate.

㉑ PULL SWP VAR

Provides continuous adjustment of A sweep TIME/DIV between calibrated positions, when the inner shaft is at pull. Counterclockwise rotation to the full delays the sweep by 2.5 times or more.

Normally, the inner shaft is left depressed.

VAR HOLD OFF

Increases the time between sweeps and aids triggering on complex displays such as high-frequency signal, irregular signal and digital

words. Rotate the VAR HOLD OFF slightly to obtain a stabilized triggering.

Normally, leave this knob rotated to MIN.

㉒ FINE
PULL ×10 MAG
POSITION

This knob is used to adjust position of the display horizontally. It is indispensable in the measurement of the time of waveform. Display is moved toward right when the knob is rotated clockwise and toward left with counterclockwise rotation. The outer shaft is for course adjustment and inner shaft for fine adjustment. A and B sweep are magnified 10 times by pulling out FINE knob (inner shaft) of POSITION. In this case the sweep time is 1/10 of the value indicated by TIME/DIV. Bring the portion of the waveform desired to be magnified observed to the outer of the scale by operating POSITION of the horizontal axis.

Next switch ×10 MAG switch to PULL (pulled out state). Then the waveform placed at the center is magnified in right and left directions. The sweep time in this case is 10 times the sweep speed obtained by TIME/DIV, in other words, the reading is 1/10 of the sweep time indicated.

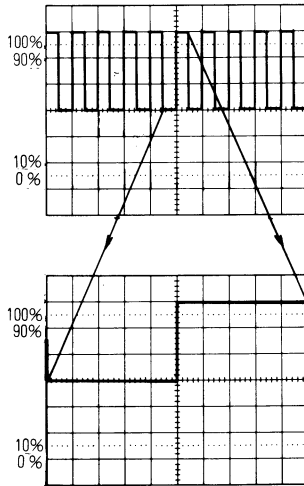

24 DLY TIME MULT

This control is used to set the delay time of B sweep starting point with respect to A sweep starting point. When the above mentioned DISPLAY is set in INTEN or B.

(4) A Triggering

25 SOURCE

This switch is used to select the triggering signal source A Sweep.

- o CH1 Used when triggering is made by observing signal for CH1
- o CH2 Used when triggering is made by observing signal for CH2.
- o LINE Used when observing a signal triggered with the frequency of mains (AC POWER).
- o EXT Used when triggering is made by a signal applied to EXT input connector, independently from observation signal.
- o EXT÷10

Attenuates external TRIG INPUT signal by a factor of 10.

26 TRIG INPUT (CH3)

Input terminal for use for external triggering signal of A sweep.

27 COUPLING

This switch is used to select the coupling mode of A sweep triggering signal.

- o AC At this setting both the DC component and the very low frequency of triggering, signal are cut off.

OHF REJ

Among the AC components of triggering signal, the high frequency components of about 4 kHz or more are attenuated. A stabilized triggering unaffected by noises of about 4 kHz or more can be obtained.

OLF REJ

Among the AC components of the triggering signal the low frequency components of less than about 4 kHz are attenuated. A stabilized triggering free from noises of less than about 4kHz can be obtained.

ODC Triggering signal is amplified unchanged.

This setting is used when triggering with a very low frequency signal or when effecting DC like triggering.

OTV-H

This setting is used when observing the entire horizontal picture of video signal.

OTV-V

This setting is used when observing the entire vertical picture of video signal.

Note Both setting will be combined with TV position on A TRIG MODE switch.

28 A TRIG LEVEL

This knob is used to decide at which portion of the waveform should the sweep the started by setting trigger level. This knob is also enabled to switch SLOPE. Depressed position (normal state) is for + SLOPE and PULL position (state in which the knob is protruding) is for - SLOPE.

* Explanation of trigger polarity SLOPE.

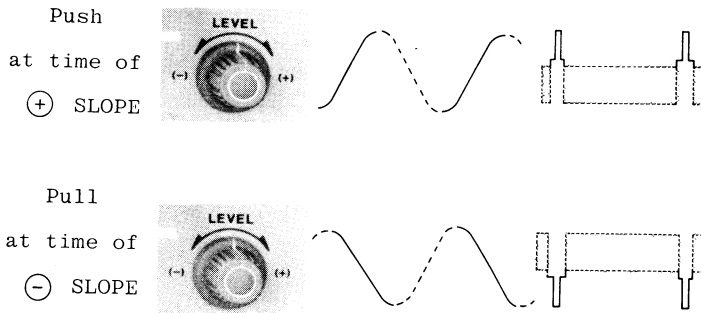

※ Explanation of trigger level LEVEL.

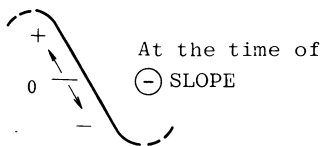
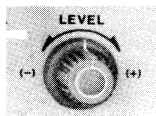
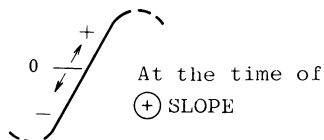
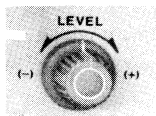

② A TRIG MODE

- AUTO The instrument is brought into automatically triggering sweep in which sweep is always conducted. In the presence of triggered signal, normal triggered sweep is obtained and the waveform stands still. In the case of no signal or out of triggering, sweep line will appear automatically. This setting is convenient in usual cases.
- NORM Triggered sweep is obtained and sweep is conducted only when triggering is effected. No sweep line will appear in the case of no signal or out of synchronization. Use this MODE when effecting synchronization to a very low frequency signal (30 Hz or less).
- SINGLE Conducts sweep for one time by trigger signal.
- READY At time of SINGLE, this lamp is lit to show the instrument is ready for single sweep. The lamp goes out when the sweep is started.
- RESET At time of SINGLE, the READY lamp goes on by depressing this switch.

- o TV Used when watching the TV (video) signal. in this case, must be select the TV-V or TV-H.

(5) B Triggering

ⓑ B TRIG (CH4) INPUT

Input terminal for external triggering signal for B sweep. Use it after setting B TRIG MODE to EXT.

ⓑ B TRIG MODE

- o AUTO B sweep is automatically started after elapsing the delay time determined by A sweep and DLY TIME POSITION. Usually, the instrument is used at this setting.

- o TRIG CH1, CH2

CH1 or CH2 trigger signal can be selected independent of A TRIG SOURCE. Moreover, In case observe the video signal, B sweep should be triggered on TV-H synchronizing signal independently of CH1 or CH2 position as following conditions.

A TRIG MODE : TV
 A TRIG COUPLING: TV-V
 B TRIG MODE : CH1 or CH2

- o TRIG EXT For external triggering. Synchronization if effected by applying the input signal itself or other signal which is integer times of input signal in time. Triggering coupling is AC fixed. This setting is used when performing delay time sweep magnification by removing jitters.

ⓑ B TRIG LEVEL

This knob is used to determinial the portion of the trigger signal of B sweep where the sweep is to be started. This knob has no relationship when B TRIG MODE is set at AUTO. Switching of slope is made simultaneously by this knob. Depressed position is for ⊕ SLOPE and PULL position for ⊖ SLOPE.

(6) Miscellaneous

- ⓑ EXT BLANKING This is a terminal for applying (BNC Connector) a blanking signal from an external source. The trace displayed on the screen may be intensity - modulated where pulse signal or

time-scale marks are required.

5V AC signal applied at the connector on the rear of the oscilloscope will provide alternate brightness and blanking of the trace. Positive voltage input decreases brightness.

34 GATE OUT A Provides a rectangular output of TTL level coincident with the A gate.

B Provides a rectangular output of TTL level coincident with the B gate.

35 CAL 0.5V Output terminal of calibration square wave of about 1kHz and 0.5V. It has a tip terminal. It is used to calibrate the probe combination.

36 GND Earth terminal of the oscilloscope.

37 Handle

The handle of the V-1050 can be positioned for carrying or as a tilt-stand for the instrument. To position the handle, press in at both pivot points and turn the handle to the desired position. Positions are provided for convenient carrying or viewing.

8. Specifications.

o CRT

Type

Hitach 150BNB31 rectangular mesh type tube with 20 kV acceleration potential and metal backed phosphor.

Screen type

P31 phosphor standard

Useful screen area

8 × 10 div (1div = 10mm)

Graticule

Internal graticule with centimeter divisions and 2mm subdivisions along the central axis 10% and 90% lines are indicated. Illumination continuously variable.

Focussing

Possible (with automatic focus correction circuit)

Trace rotation Present

Scale illumination Variable

Brightness adjustment Possible

o Z-AXIS

DC-coupled, positive-going signal decreases intensity: 5Vp-p

Signal causes noticeable modulation at normal intensity: DC to 3.5MHz.

Input impedance Approximately 15 kΩ

Maximum input voltage 20 V (DC + AC peak)

Coupling DC

o VERTICAL DEFLECTION (2 Identical Channels)

Bandwidth and Rise time

DC to at least 100MHz and rise time 3.5ns or less. DC to at least 5MHz and rise time 70ns or less at magnifier extends.

Lower -3dB point, AC coupling 10Hz or less.

Deflection Factor

5mV/div to 5V/div in 10 calibrated steps, 1-2-5 sequence. Uncalibrated continuous control extends deflection factor to at least 12.5 Volts per division in the 5 Volts/div position. x10 magnifier increases sensitivity of each deflection factor setting to 500μV/div.

Accuracy

x1 ±2% (+10°C to +35°C) ±4% (0°C to +50°C)

x10 ±3% (+10°C to +35°C) ±5% (0°C to +50°C)

Additional error for magnifier ±1%

Display modes

CH1, CH2 (normal or invert), Alternate, Chopped (250kHz rate), Added

Input Impedance

1M ohm ±1.5% in parallel with 28pF ±3PF.

Maximum Input Voltage

250V (DC + AC peak) or 500Vp-p AC at 1kHz or less

Input coupling

AC-GND-DC

Delay Line

Permits viewing leading edge of display waveform.

Four-trace Display (TRIG VIEW)

Display simultaneously channel 1, channel 2, channel 3 (A EXT TRIG signal), channel 4 (B EXT TRIG signal).

The deflection factor of channel 3 and channel 4 is approx. 200mV/DIV.

- Sensitivity INT: $1/1 \pm 30\%$ of screen area
EXT: $0.2 \text{ V/DIV} \pm 30\%$
- Frequency band EXT: DC to 70 MHz (-3dB)
- Position CH3: Horizontal 100% graticule line of screen ± 1 div (trigger level knob is set at the center).
CH4: Horizontal 0% graticule line of screen ± 1 div.

o HORIZONTAL DEFLECTION

Time Base A

20ns/DIV to 0.5s/DIV in 23 calibrated steps, 1-2-5 sequence. Uncalibrated continuous control

extends deflection factor to at least 1.25 seconds per division in the 0.5 s/DIV position. x10 mag extends fastest sweep rate to 2ns/DIV.

Time Base B

20ns/DIV to 50ms/DIV in 20 calibrated steps 1-2-5 sequence. x10 mag extends fastest sweep rate to 2ns/DIV.

Accuracy

$\pm 2\%$ (+10°C to +35°C)

$\pm 4\%$ (0°C to +50°C)

Additional error for magnifier $\pm 2\%$.

A sweep variable Present

Horizontal Display Modes

A only, A intensified, Alternate, B delayed, X-Y operation.

Delayed sweep position 1 div or less ~ 10 div adjustment or more

Delay Time Jitter Better than 1:20,000

o TRIGGERING A AND B

A Trigger Modes

Automatic, Normal, Single sweep, TV (TV-H or TV-V)

A Trigger Hold-off

Adjustable control permits a stable presentation of repetitive complicated waveform.

A Trigger Source

Internal (Ch1, Ch2), Line, External, External
÷ 10

A Trigger Slope

+ or -

TV Sync Polarity

TV(+) or TV(-)

Triggering level For both A and B. Internal;
variable range +4div or more

External; approximately +1V

External÷10; approximately
+10V

Triggering sensitivity and frequency () is only for B

Frequency	Internal	External	External÷10
DC(30Hz) ~ 10MHz	0.3 div	50 mV	500 mV
10 MHz ~ 100MHz	1.5 div	150 mV	1.5 V

TV-V sensitivity: SYNC section less than 0.7div
or 200mV

AUTO low band : Approximately 30Hz (When Time
Base A is 20ns/DIV to 2ms/DIV)

A Trigger Coupling

AC : 30Hz to full bandwidth

HF REJ: attenuates signals below approx 4kHz

LF REJ: attenuates signals above approx 4kHz

DC : 0 to full bandwidth

A External Trigger Input Impedance

1M ohm +20% in parallel with 28PF +6PF (However,
setting HF REJ and LF REJ are not included.)

Maximum Input Voltage

250V (DC + AC peak at 1kHz or less)

500Vp-p AC at 1kHz or less

B Trigger Modes and Source

Automatic, Normal (Ch1, Ch2, External)

B Trigger Slope

+ or -

Trigger Coupling

AC only; 30Hz to full bandwidth

o X-Y OPERATION (CH1; Horiz. CH2; Vert.)

Deflection Factor

Same as vertical deflection

Accuracy

Y: ±2% (+10°C to +35°C), +4% (0°C to +50°C)

X: ±5% (+10°C to +35°C), ±7% (0°C to +50°C)

X-Bandwidth

DC to at least 2MHz

Phase Error

3° or less from DC to 2MHz

o CALIBRATOR

0.5V \pm 1% Frequency 1kHz \pm 1% square wave

Rise time 5 μ s or less

o OUTPUT SIGNALS

A GATE OUT TTL OUTPUT (74LS00 with OUTPUT series
resistance 100 Ω)

B GATE OUT TTL OUTPUT (7400 with OUTPUT series
resistance 100 Ω)

o POWER SUPPLY

VOLTAGE (50/60Hz)	FUSE
100 V (90 ~ 110 V)	2A
120 V (108 ~ 132 V)	2A
220 V (199 ~ 242 V)	1A
240 V (216 ~ 264 V)	1A

Nominal voltage \pm 5% at 400Hz

o Power supply

Power supply frequency 50, 60, 400Hz

Power consumption Approximately 60W

o ENVIRONMENT

Limit of operation temperature 0 $^{\circ}$ C ~ 50 $^{\circ}$ C

Limit of operation humidity 35% ~ 85%

Rated range of use temperature 10 $^{\circ}$ C ~ 35 $^{\circ}$ C

Rated range of use humidity 45% ~ 85%

Storage temperature -20 $^{\circ}$ C ~ +70 $^{\circ}$ C

o DIMENSION AND WEIGHT

310w \times 180h \times 410d mm

(12.2w \times 7.1h \times 16.1d in)

10.2kg (22.5 lbs)

9. Users Adjustments

(1) TRACE ROTATION

Adjust the TRACE ROTATION on the front panel when slight tilting of the trace is caused by the effect of external magnetic fields.

Make certain that tilting of the traces is not caused by the effect of unusually strong external magnetic fields due to the position of the oscilloscope.

(2) ASTIG ADJUSTMENT

Set the knob DISPLAY switch to X-Y , and MODE switch to CH2 X-Y observing the spot on the center of the screen.

RV1038 astigmatism adjustment provides optimum spot POWER/INTENSITY roundness when used in conjunction with FOCUS and POWER/INTENSITY control. Little readjustment of this control is required after initial adjustment.

(3) Adjust VOLTS/DIV Balance (DC BAL)

- a. Position the trace to the center horizontal line with the vertical POSITION control.
- b. Check-Change the VOLTS/DIV switch from 5mV to 10mV. Trace should not move more than 0.1 division.
- c. Adjust RV7(CH1), or RV107(CH2) for minimum trace

shift when rotation the VOLTS/DIV switch from 5m volt to 10m volt. If necessary, rotate the vertical position control to keep the trace in the center of the screen.

(4) Vertical GAIN Adjustment

- a. Set the VOLTS/DIV for 10mV/DIV.
Connect the CAL .5 V output to the CH1 or CH2 connector with probe.
- b. Check-CRT display for five divisions of deflection.
- c. Adjust the GAIN controls, RV339(CH1) or RV160 (CH2), for exactly five divisions of deflection.

Please refer to section 10. schematic diagrams.

10. Schematic Diagram

- Note
1. All of the basic circuit diagram are subject to change without notice.
 2. All resistor values in ohm: 1/4W and all capacitor values in micro farad unless indicated.
 3. * Resistor selected values.

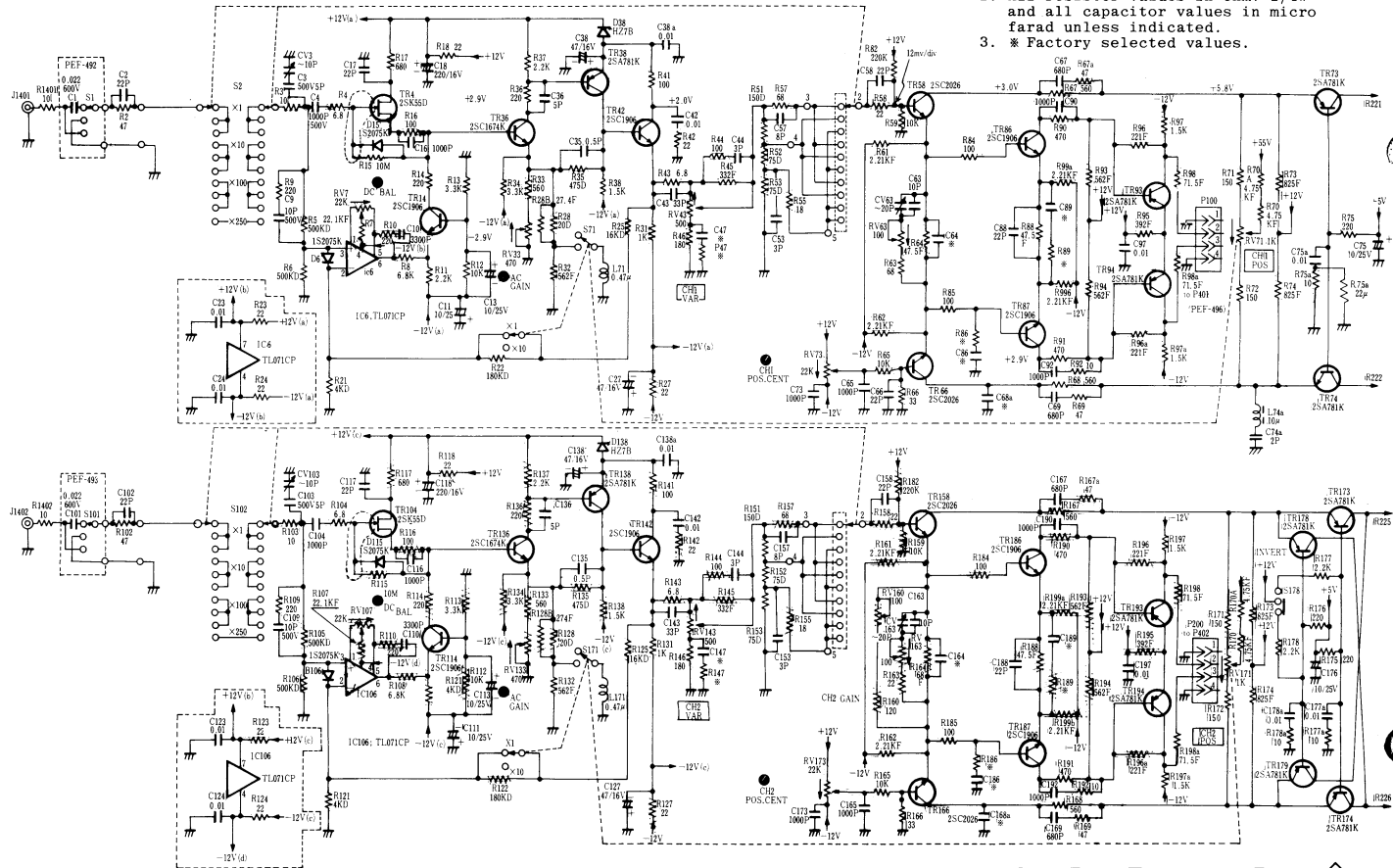

SCHEMATIC DIAGRAM ◊
[VERTICAL PREAMPLIFIER]

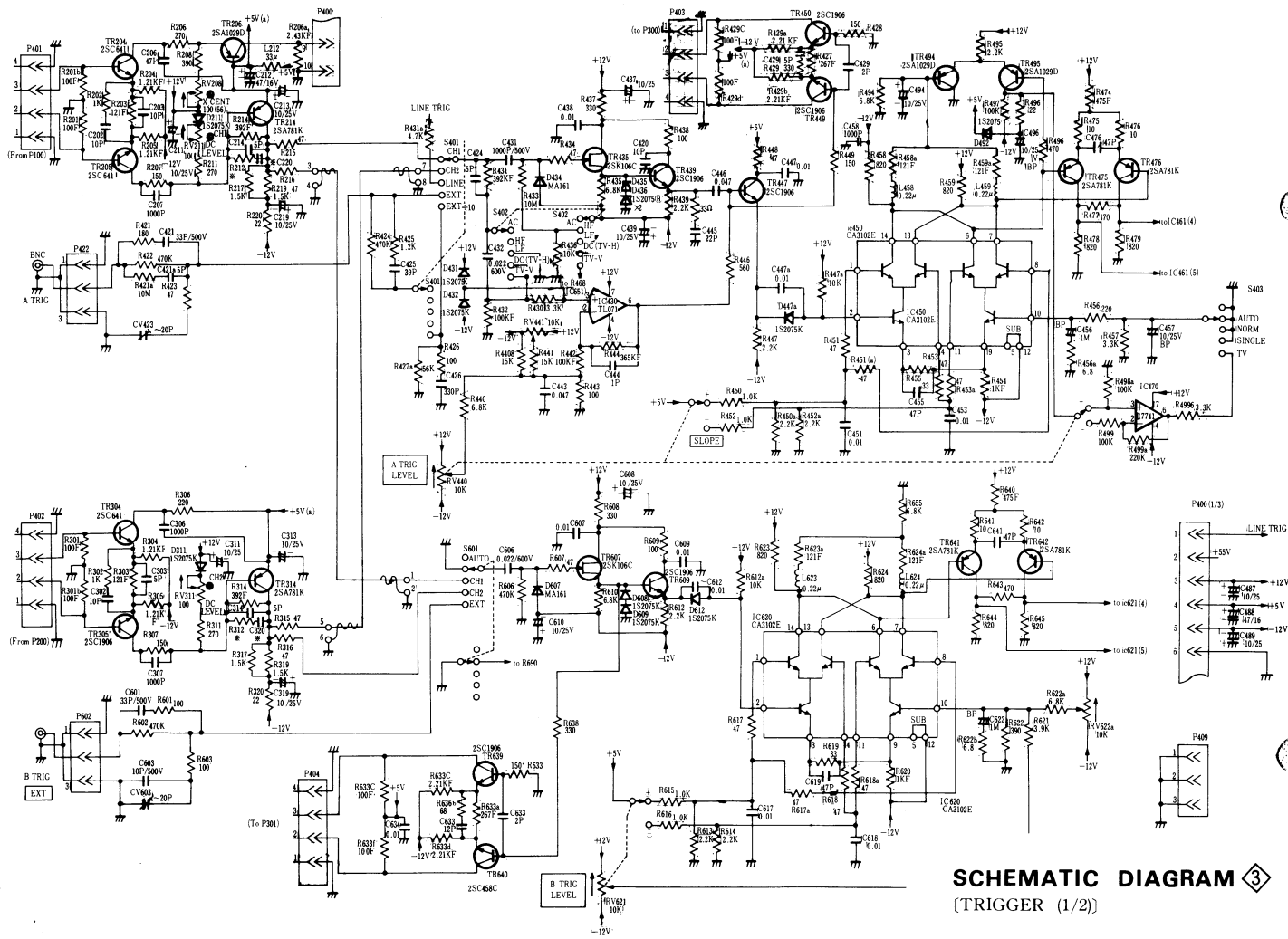

SCHEMATIC DIAGRAM [TRIGGER (1/2)]

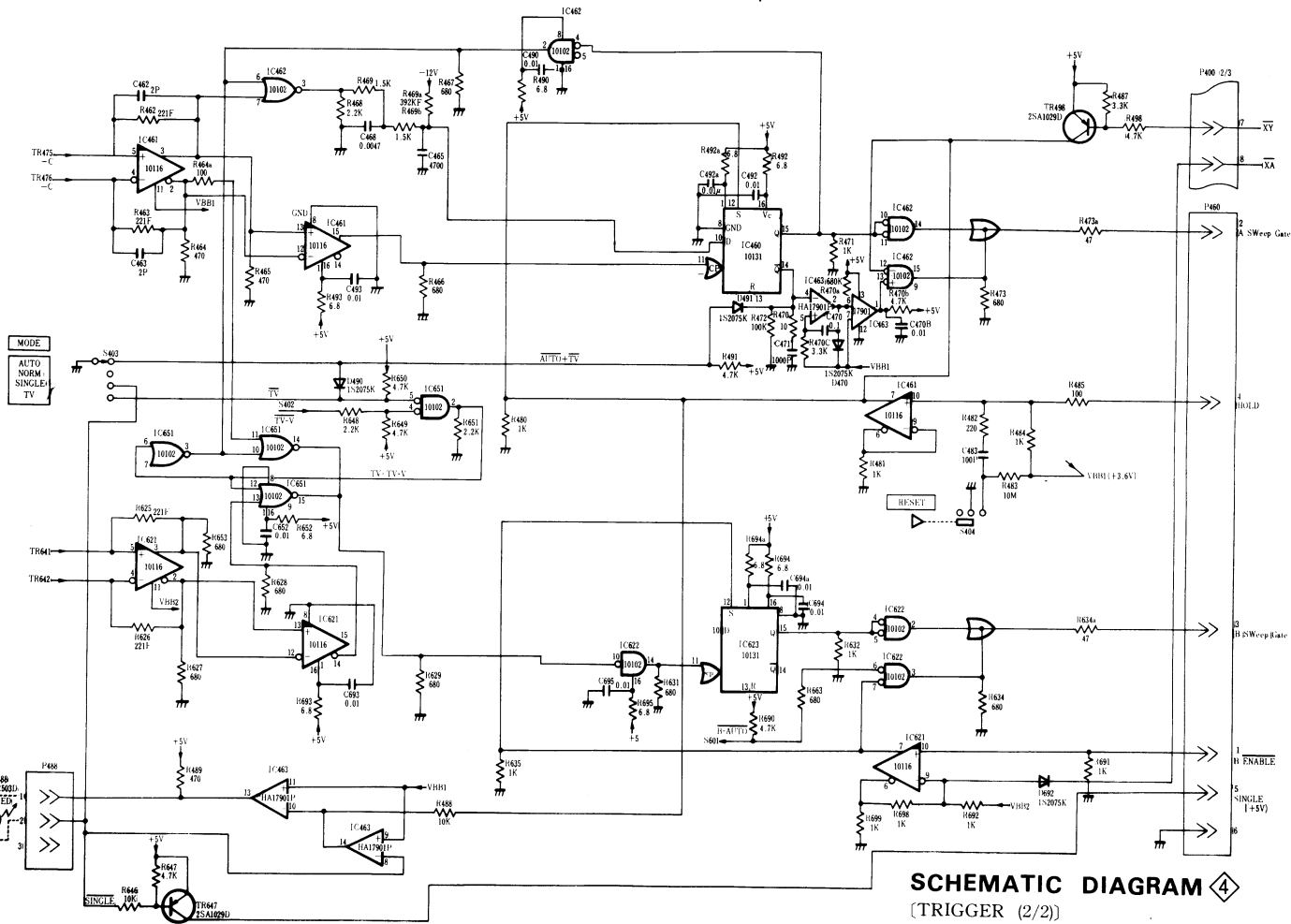

SCHEMATIC DIAGRAM 
 (TRIGGER (2/2))

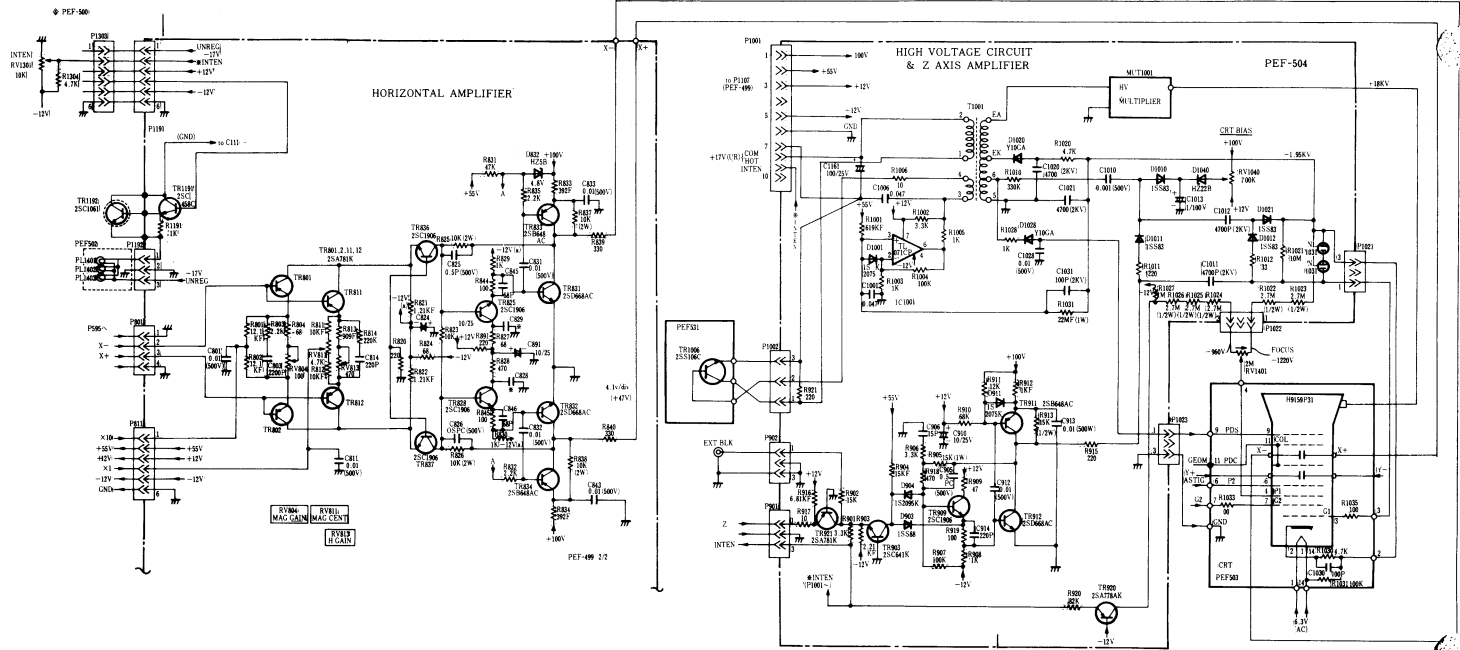

SCHEMATIC DIAGRAM 
 (HORIZONTAL AMPLIFIER,
 Z-AXIS AMPLIFIER
 & HIGH VOLTAGE CIRCUITS)

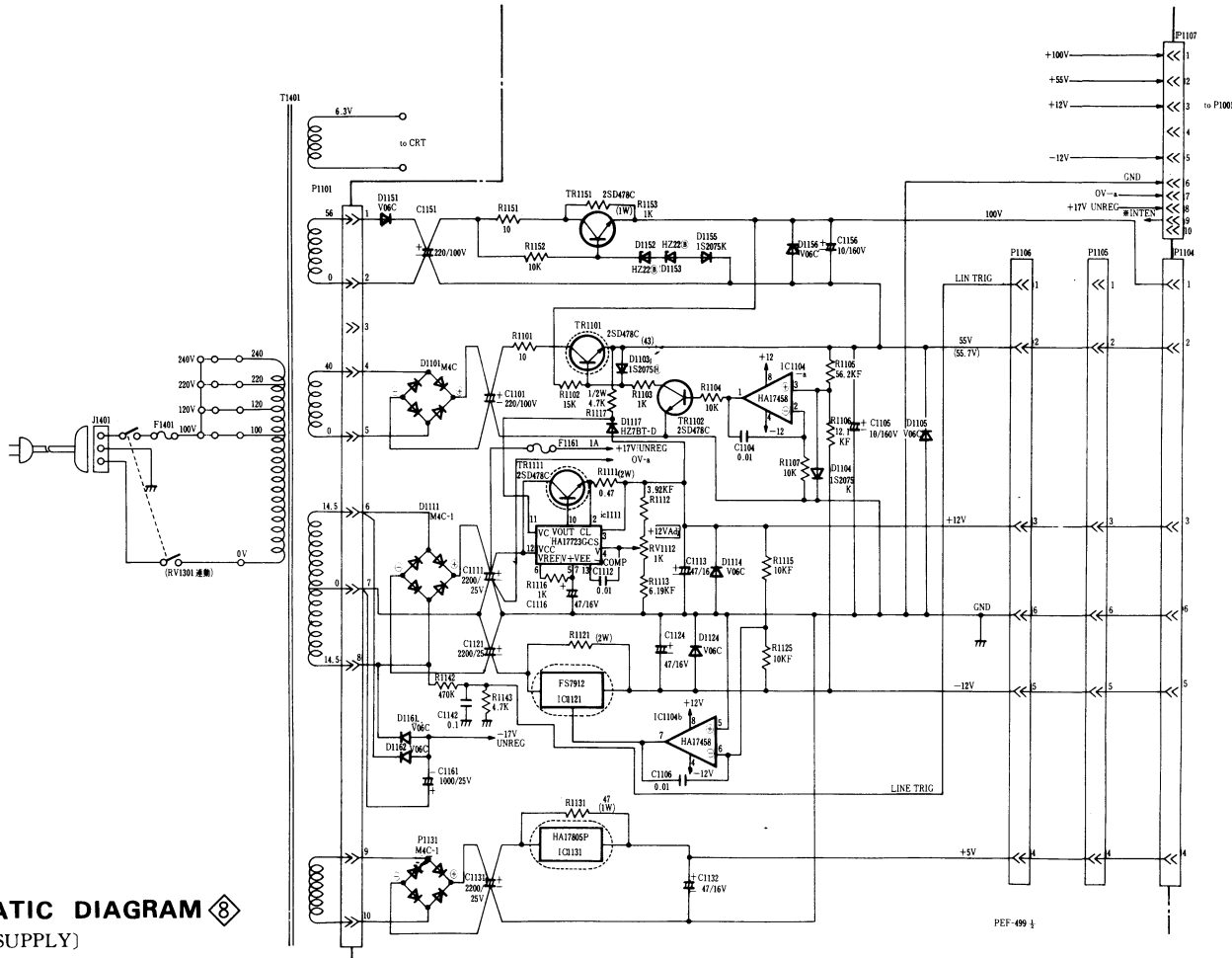

SCHEMATIC DIAGRAM 
 (POWER SUPPLY)

PEF-499 4

(2) Rear panel

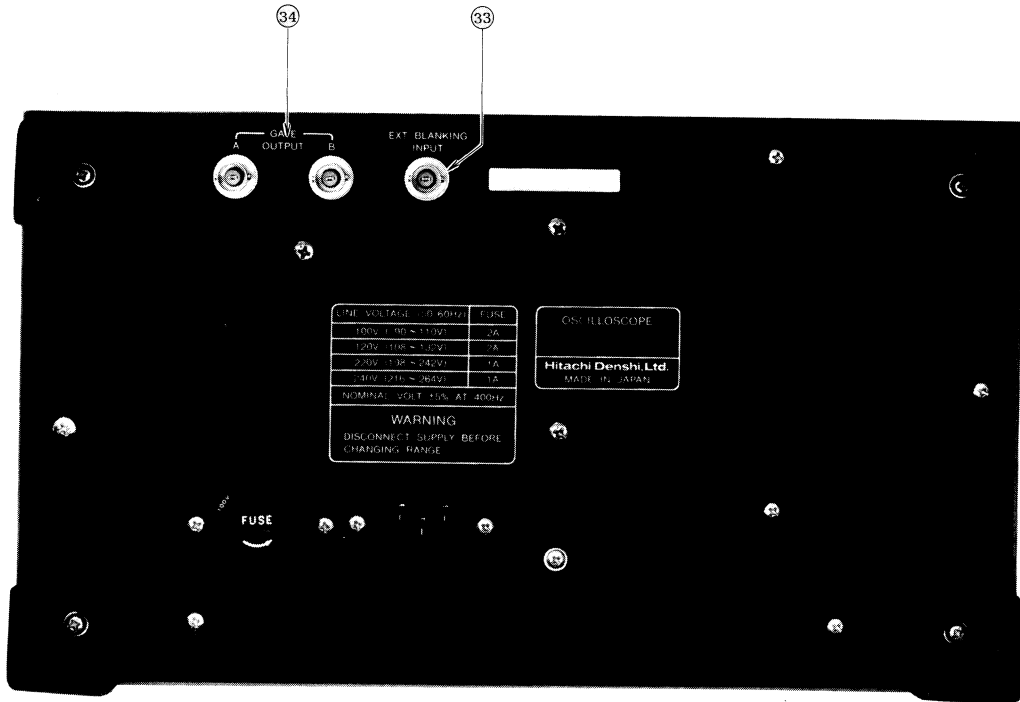

11. Panel controls

(1) Front panel

